



LOWFLOW
a division of Jordan Valve

3170 Wasson Road • Cincinnati, OH 45209 USA
Phone 513-533-5600 • Fax 513-871-0105
lowflow@richardsind.com • www.lowflowvalve.com

I & M 6800HP Series

Installation & Maintenance Instructions for Mark 6800HP High Pressure Regulators

Warning: Low Flow Regulators must only be used, installed and repaired in accordance with these Installation & Maintenance Instructions. Observe all applicable public and company codes and regulations. In the event of leakage or other malfunction, call a qualified service person; continued operation may cause system failure or a general hazard. Before servicing any valve, disconnect, shut off, or bypass all pressurized fluid. Before disassembling a valve, be sure to release all spring tension.

Please read these instructions carefully!

Your LowFlow/Jordan product will provide you with long, trouble-free service if it is correctly installed and maintained. Spending a few minutes now reading these instructions can save hours of trouble and downtime later. When making repairs, use only genuine LowFlow Valve parts, available for immediate shipment from the factory.

Ideal Installation Schematic

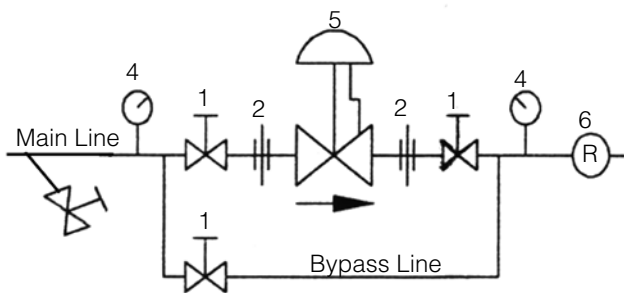

1. Shut-off valve
2. Pipe union
3. Strainer/drain valve
4. Pressure gauge
5. Jordan regulator
6. Relief valve

Preferred Installation

1. To protect the valve from grit, scale, thread chips and other foreign matter, ALL pipelines and piping components should be blown out and thoroughly cleaned before the installation process begins.
2. Shutoff valves, pressure gauges and by-pass piping should be installed as indicated in the **Ideal Installation Schematic** to provide easier adjustment, operation and testing.
3. When preparing threaded pipe connections, care

should be exercised to prevent pipe sealing compound from getting into the pipe lines. Pipe sealing compound should be used sparingly, leaving the two lead threads clean. Jordan Valve uses, and recommends, thread sealer Teflon ribbon.

4. A line strainer should be installed on the inlet side of the regulator to protect it from grit, scale, and other foreign matter. A 0.033 perforated screen is usually suitable. Line strainers are available from Jordan Valve.
5. The flow arrow on the valve body must be pointed in the direction of the flow. The regulator may be installed vertically or horizontally without affecting its operation.
6. For best control, 3'0" straight sections of pipe should be installed on either side of the regulator.
7. In hot vapor lines, upstream and downstream piping near the regulator should be insulated to minimize condensation.
8. If possible, install a relief valve downstream from the regulator. Set at 15 psi above the control point of the regulator.
9. In gas service, expand the outlet piping at least one pipe size, if the control pressure (downstream) is 25% of the inlet pressure or less. A standard tapered expander connected to the outlet of the valve is recommended.
10. Where surges are severe, a piping accumulator is recommended.
11. Operate the regulator within its rated pressure and temperature.

Start-Up

With inlet, outlet, and by-pass shutoff valves closed, and no pressure the downstream line:

1. Fully open the outlet shutoff valve.
2. Slowly open the inlet shutoff valve.
3. Slowly open and close the outlet shutoff valve

several times. This fully strokes the valve to insure satisfactory operation.

4. With the outlet shutoff valve open, slowly screw down the adjusting screw until the desired pressure is shown on the outlet pressure gauge.
5. To change the controlled pressure, turn the adjusting screw clockwise to increase the pressure, counter-clockwise to decrease pressure.

Warning: Never substitute a longer length adjusting screw. Personal injury and/or damage to the valve may result.

Maintenance

Caution: Make certain that there is no pressure in the valve before loosening any fittings or joints. The following steps are recommended:

1. Close the inlet shutoff valve.
2. Allow pressure to bleed off through the downstream piping. Do not attempt to reverse the flow through the valve by bleeding pressure from the upstream side of the valve.
3. When the pressure gauges indicate that all pressure has been removed from the system, close the outlet shutoff valve, and the valve may be serviced.

Valve Disassembly

1. Load the range spring by turning adjusting screw (28) clockwise at least five full turns. This will help prevent damaging the seat during disassembly.
2. Remove the bottom cap (1).
3. Remove the trim subassembly and the return spring (3) from the bottom cap (1).
4. Remove the o-ring (5) and the back-up rings (4) from the bottom cap (1).
5. Unthread the seat retainer (8) from the guide (2). Remove the o-ring (14).
6. For valves with balanced trim, remove the o-ring (35) and back-up rings (36) from the guide.
7. Remove the retaining ring (7) from the stem (12) and disassemble the stem and seat (10) from the seat retainer (8).
8. Unload the range spring by turning the adjusting screw (28) counter-clockwise.
9. Remove the eight socket head cap screws (24) and remove the spring housing (13).
10. Remove the upper spring guide (26), the range spring (25), the lower spring guide (23) and the ball bearing (22).

11. Remove the cylinder (18) from the body (6) and remove the piston (19) from the cylinder.
12. Remove the o-rings (20 & 17) and the back-up rings (16 & 21) from the piston (19) and cylinder (18).
13. Remove the orifice (11) from the body (6). Remove the o-ring (15) from the orifice.

Valve Assembly

1. Lubricate and place o-ring (15) into the groove on the orifice (33) being careful not to cut o-ring on threads.
2. Apply Loctite No. 242 to threads and install orifice (11) into body. Torque to 25 ft-lbs.
3. Lubricate and place o-ring (17) with two back-up rings (16) into the groove on the piston (19).
4. Lubricate and place o-ring (20) with two back-up rings (21) into groove on the cylinder (18).
5. Insert the piston (19) through the chambered side of the cylinder (18) just enough to compress the o-ring on the piston. The end of the piston with the o-ring should go into the cylinder first.
6. Install the cylinder (18) into the body (6).
7. Drop the ball (22) into the piston (19).
8. Install the lower spring guide (23) (into the piston (19)). Push the piston into the cylinder until the lower spring guide seats against the cylinder.
9. Place the range spring (25) onto the lower spring guide (23).
10. Place the upper spring guide (26) onto the range spring (25).
11. Install the spring housing (13) onto the body with eight socket head cap screws (24). The spring housing should pilot squarely onto the cylinder. Torque the screws to 32 ft-lbs. See torque sequence diagram under Torquing Procedures.
12. Thread the hex jam nut (27) onto the adjusting screw (28).
13. Place the shims onto the adjusting screw (28) and thread it into the spring housing (13) until it makes contact with the upper spring guide (inside the spring housing). Use the same shims that were originally installed on the valve. Do not alter the thickness or the valve may fail to operate properly.
14. Thread the adjusting screw (28) into the spring housing (13) until it just makes contact with the upper spring guide (inside the spring housing).
15. Load the range spring by turning the adjusting screw clockwise five full turns. This step is important in preventing damage to the seat while installing the bottom cap and trim in the next section.

Trim

1. Lubricate and place the o-ring (5) and two back-up rings (4) into the groove on the bottom cap (1) being careful not to cut the o-ring on the threads.
2. Place the return spring (3) into the bottom cap (1).
3. Lubricate and insert the o-ring (9) into the seat retainer (8).
4. Insert the seat (10) into the seat retainer (8).
5. Install the stem (12) through the seat (10) and seat retainer (8). Secure in place with retaining ring (7).
6. Lubricate and place the o-ring (14) into the groove on the guide (2) being careful not to cut the o-ring on the threads. If the valve has balanced trim, lubricate and place the o-ring (35) and two back-up rings (36) into the groove on the guide (2).
7. Apply Loctite No. 242 onto the threads of the guide (2) and thread into the seat retainer (8). Tighten the seat retainer until it is seated firmly against the guide.
8. Place the completed trim subassembly into the bottom cap (1). The stem (12) should be facing out.
9. Apply Loctite No. 242 onto the threads of the bottom cap (1) and thread into the body (6). The stem (12) should locate into the hole in the bottom of the piston (19). Tighten the bottom cap until it is seated firmly against the stop in the body.

Torque Procedures

1. Install all bolts hand-tight.
2. Torque the bolts in order of the bolt pattern to a value equal to 1/4 of the recommended torque value.
3. Restore each bolt to 32 ft-lbs using the same bolt pattern as shown.

Bolt Pattern/Torque Sequence
(8 bolts or multiples)

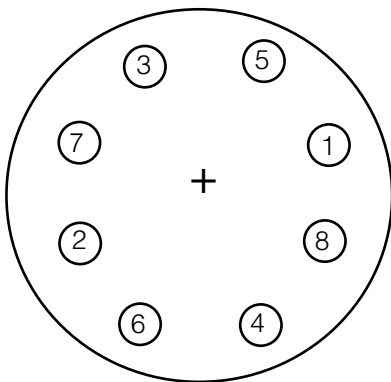

Troubleshooting

Symptom

Possible Cause and Cure

- **Erratic Control**

1. Oversizing causes cycling and hunting and reduces the rangeability of the valve. Make certain that your sizing is correct.
2. Safety valve may be jammed open. Repair as necessary.
3. Excessive foreign matter on seat (10) or orifice (11). Clean them. Inspect seating surfaces for deterioration.
4. Valve trim may not be moving freely. Check for any parts that may be binding.

- **Downstream Pressure Build-Up**

1. Seats deteriorated. Replace.
2. Inspect for foreign matter between the seat (10) and orifice (11).
3. Metal hard seat not supplying tight enough shutoff. Consider using soft seat.
4. O-ring (9, 14 or 15) not sealing. Replace.

- **Cannot Maintain Regulated Pressure**

1. Inlet pressure too low.
2. Clogged strainer or lines. Clean.
3. Spring (25) set too low or broken. Reset or replace.
4. Valve is undersized for rated flow. Recheck sizing.
5. System demand exceeds capacity. Recheck sizing.

Troubleshooting

Low Flow Valves are ruggedly built, carefully assembled to accurate dimensions, and individually tested for performance. A complete stock of finished parts is maintained ready for immediate shipment.

If desired, Low Flow Valve will promptly repair your regulator at a reasonable cost. To return a valve for inspection and/or repair, please contact our customer service department for a Return Authorization Number. Phone toll-free at 1-800-543-7311. If preferred, you may fax us at 513-871-0105.

When ordering spare parts, first make a note of the following information on the valve's nameplate:

- serial number
- model number and size
- body material and end connections
- range
- seat and seal materials

Cross Section View

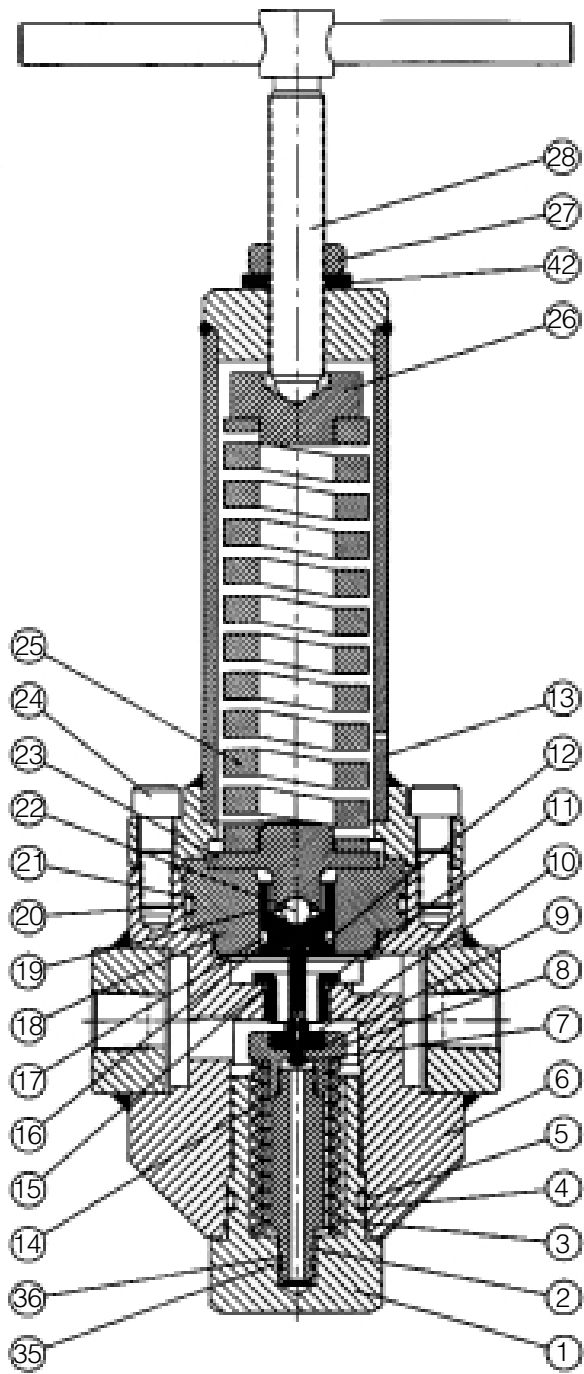

Balanced Trim

Item No.	Description	Quantity
1	Body Cap	1
2	Guide	1
3	Spring	1
4*	Back-Up Ring	2
5*	O-Ring	1
6	Body	1
7*	Retaining Ring	1
8*	Seat Retainer	1
9*	O-Ring	1
10*	Seat	1
11*	Orifice	1
12*	Stem	1
13	Spring Housing Subassembly	1
14*	O-Ring	1
15*	O-Ring	1
16*	Back-Up Ring	2
17*	O-Ring	1
18	Cylinder	1
19	Piston	1
20*	O-Ring	1
21*	Back-Up Ring	2
22	Ball Bearing	1
23	Lower Spring Guide	1
24	Socket Head Cap Screw	8
25	Spring	1
26	Upper Spring Guide	1
27	Hex Jam Nut	1
28	Adjusting Screw Subassembly	1
35*	O-Ring	1
36*	Back-Up Ring	2
42*	Shim	1

* Recommended Spare Parts

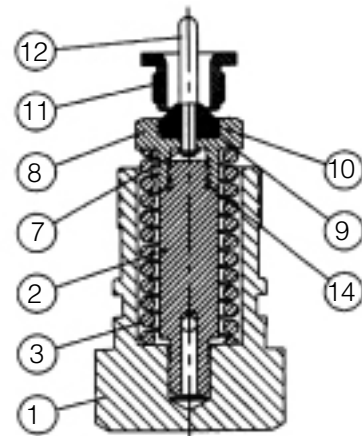

Un-Balanced Trim