

Delta Element Steam Traps

Models: M22, TM22

CRN: Canadian Registration Number Available

STEAM TRAPS FOR SUBCOOLING TRACING APPLICATIONS

3 Year No Live Steam Loss Guarantee

Specifically developed to make use of the latent heat of steam and the sensible heat of condensate prior to discharge. For critical tracing applications.

- **Maximum differential pressure:** 300 psi (20,7 bar)
- **No live steam loss:** for greater energy efficiency and extended seat life
- **Single blade element** – offers long-term, trouble-free service because it's not prone to dirt build-up as encountered with many other bimetal designs
- **Easy maintenance** – traps are in-line repairable when isolated from live steam system and can be up and running again in minutes
- **Stainless Steel internals** – leads to longer service life since materials are highly resistant to fatigue and corrosion
- **Modulating discharge** – automatically adjusts to operating pressure and load
- **Built-in check valve** – prevents backflow during shutdown
- **Continuous air and CO2 venting** – maximizes heat transfer while minimizing corrosion

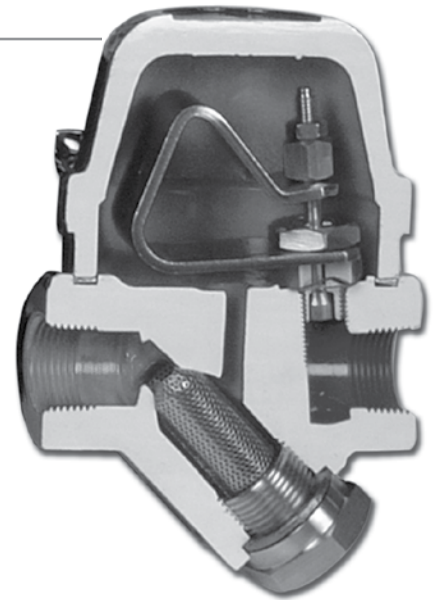

ORDERING SCHEMATIC

MODEL				6	7	8
M	0	0	2	2		

MODEL				6	7	8
T	M	0	2	2		

6	SIZE
1	3/8"
2	1/2"
3	3/4"

7	CONNECTIONS
1	NPT (All)
2	FSW (All)
3	150# Flange (M22)
4	300# Flange (M22)
5	600# Flange (M22)
8	BSPT (All)
9	BSPP (All)

8	SPECIALITIES
0	None (All)
1	DTC (M22)
3	Integral Blowdown (M22)



A Division of
Richards Industries
3170 Wasson Road
Cincinnati, OH 45209

toll free. 800.543.7311
local. 513.533.5600
fax. 513.871.0105

steam@richardsind.com
www.bestobellsteamtraps.com

STEAM TRAPS FOR SUBCOOLING TRACING APPLICATIONS

SPECIFICATIONS

Maximum Differential Pressure: 300 psi (20,1 bar)

Maximum Allowable Pressure: 750 psig (51,7 bar)

Maximum Allowable Temperature: 750°F (399°C)

MATERIALS

Body & Cover: Forged Carbon Steel A105

Valve Seat: 303 SST

Stem: 17-4 SST

Bi-Metal: Stainless Steel NiCr

Strainer: Stainless Steel 304

Bolts: ASTM-A193, B7

Gasket: Flexible Graphite

Options: Double Threaded Strainer Cap (DTC) for blowdown valve attachment; selection of integral blowdown valves (M22 only)

Mounting: From horizontal to vertical (see Installation & Maintenance Instructions). Self-Draining and freeze-resistant when mounted in vertical position.

Line Sizes: 3/8", 1/2", 3/4"

End Connections:

All models: NPT, BSPT, BSPP, SW

M22: Raised faced flanges (150, 300, 600)

BENEFITS OF THE DELTA ELEMENT DESIGN

The combination of thermostatic and thermodynamic forces make the Bestobell Delta Element steam traps more than a match for the steam curve. They are designed (and factory pre-set) to match virtually all of your applications and plant requirements - whether for tracing, dripleg, process, heating, or even high pressure service. Following the steam curve is the key to efficient steam trap performance as it provides you with the most energy efficient operation. The balanced pressure control operation of the Bestobell Delta Element trap matches the steam curve and allows efficient trap operation over wide pressure ranges.

CAPACITY CHARTS: CONDENSATE CAPACITY AT OPERATING PRESSURE

Model M22 & TM22		Note: Actual flow rate from tracer line determines the amount of subcooling of condensate					
Size	Operating Pressure, psi (bar)	50 (3,5)	100 (6,9)	150 (10,3)	200 (13,8)	250 (17,2)	300 (20,7)
3/8"	Hot @ 50°F subcooling lbs/hr	50	50	50	50	50	50
	Hot @ 90°F subcooling lbs/hr	250	250	250	250	250	250
1/2"	Hot @ 10°C subcooling kgs/hr	22,7	22,7	22,7	22,7	22,7	22,7
	Hot @ 32°C subcooling kgs/hr	113	113	113	113	113	113

Note: Flow rates are based on discharge to atmospheric pressure, valid for back pressure up to 20% of inlet pressure. Higher back pressure requires reset of control element to obtain these capacities. Consult factory for details.

M22/TM22/0814

MODEL TM22 DIMENSIONS

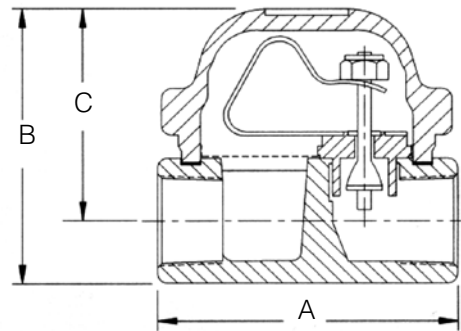

Model TM22						
3/8", 1/2"	A	B	C	D	Wt	
inches	2.438	2	2.25	2.438	2.2 lbs	
mm	62	51	57	62	1,0 kgs	
3/4"	A	B	C	D	Wt	
inches	4.563	3.125	2.25	2.438	3.0 lbs	
mm	116	79	57	62	1,4 kgs	

MODEL M22 DIMENSIONS

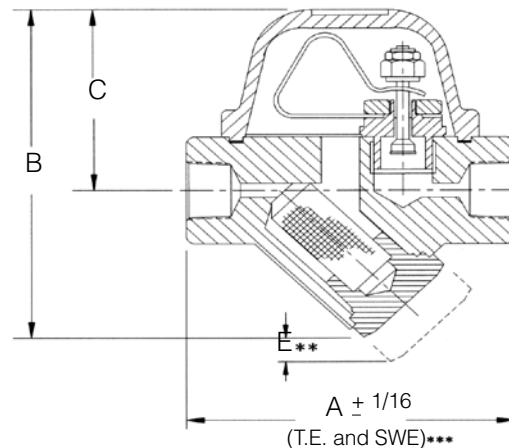

Model M22						
3/8", 1/2", 3/4"	A	B	C	D	E	Wt
inches	4	5	3.75	3.125	2.25	5.5 lbs
mm	102	127	83	79	57	2,5 kgs

Notes: dimension D is overall width; ** dimension E is withdrawal distance for strainer, ***dimensions shown are for threaded or socket weld ends, contact factory for other dimensions