

## Delta Element Steam Traps

Models: M25, GM25

CRN: Canadian Registration Number Available

### FOR PROCESS AND HEATING SYSTEMS

#### 3 Year No Live Steam Loss Guarantee

A series of high pressure, compact, high capacity steam traps developed to handle the varying loads typical of process and heating applications.

- **Maximum differential pressure:** 320 psi (22,1 bar)
- **Single blade element** – offers long-term, trouble-free service because it's not prone to dirt build-up as encountered with many other bimetal designs
- **Easy maintenance** – traps are in-line repairable when isolated from live steam system and can be up and running again in minutes
- **Stainless Steel internals** – leads to longer service life since materials are highly resistant to fatigue and corrosion
- **Modulating discharge** – automatically adjusts to operating pressure and load
- **Integral strainer and check valve** – strainer protects trap from dirt while check valve prevents backflow during shutdown
- **Continuous air and CO2 venting** – maximizes heat transfer while minimizing corrosion

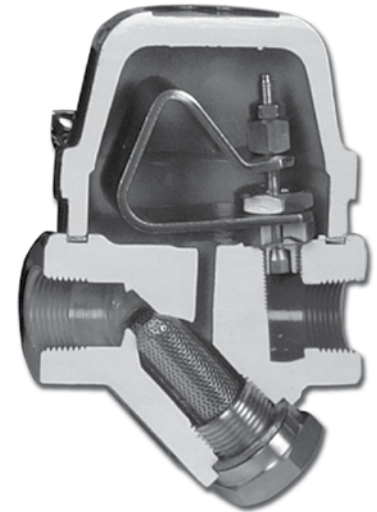

### ORDERING SCHEMATIC

MODEL					6	7	8
M	0	0	2	5			

MODEL					6	7	8
G	M	0	2	5			

6	SIZE
2	1/2" (All)
3	3/4" (All)
4	1" (M25)
6	1-1/2" (M25)
7	2" (M25)

7	CONNECTIONS
1	NPT
2	FSW
3	150# Flange
4	300# Flange
5	600# Flange
8	BSPT
9	BSPP

8	SPECIALITIES
0	None
1	DTC
3	Integral Blowdown



A Division of  
Richards Industries  
3170 Wasson Road  
Cincinnati, OH 45209

toll free. 800.543.7311  
local. 513.533.5600  
fax. 513.871.0105

steam@richardsind.com  
www.bestobellsteamtraps.com

**FOR PROCESS AND HEATING SYSTEMS**
**SPECIFICATIONS**

Maximum Differential Pressure: 320 psi (22,1 bar)

Maximum Allowable Pressure: 750 psig (51,7 bar)

Maximum Allowable Temperature: 750°F (399°C)

**MATERIALS**

Body & Cover: Forged Carbon Steel A105

Valve Seat 303 SST & Stem: 17-4 SST

Bi-Metal: Stainless Steel NiCr

Strainer: Stainless Steel 304

Bolts: ASTM-A193, B7

Gasket: Flexible Graphite

Options: Double Threaded Strainer Cap (DTC) for blowdown valve attachment; selection of integral blowdown valves

Mounting: From horizontal to vertical (see Installation & Maintenance Instructions). Self-Draining and freeze-resistant when mounted in vertical position.

**Line Sizes:**

Model M25: 1/2", 3/4", 1", 1-1/2", 2"

Model GM25: 1/2", 3/4"

End Connections: Threaded NPT, BSPT, BSPP, SW, Raised Face Flanges (ANSI 150, 300, 600, DIN)

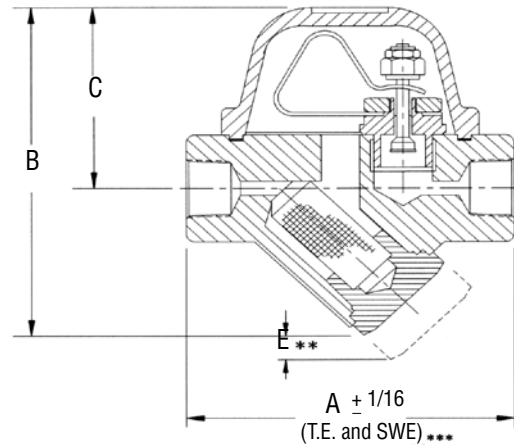

Model M25						
1/2"-3/4"	A	B	C	D	E	Wt
inches	4.125	6.125	3.625	4	2.625	8.4 lbs
mm	105	156	92	102	67	3,8 kgs
1"	A	B	C	D	E	Wt
inches	5	6.75	3.625	4	3.50	9.9 lbs
mm	127	171	92	102	89	4,5 kgs
1-1/2", 2"	A	B	C	D	E	Wt
inches	7.125	9.50	6	6	4.375	33 lbs
mm	181	241	152	152	67	15 kgs
Model GM25						
1/2" - 2"	A	B	C	D	E	Wt
inches	4	6	3.625	4	2.625	8.4 lbs
mm	102	152	92	102	67	3,8 kgs

Notes: dimension D is overall width; \*\* dimension E is withdrawal distance for strainer, \*\*\* dimensions shown are for threaded or socket weld ends, contact factory for other dimensions

**CAPACITY CHARTS: CONDENSATE CAPACITY AT OPERATING PRESSURE**

Model M25		Consider "10" series traps in this range			
Size	Operating Pressure, psi (bar)	150 (10,3)	200 (13,8)	250 (17,2)	320 (22,1)
1/2"	Cold start-up, lbs/hr	4000	5000	6000	6200
	Hot (Dripleg), lbs/hr	160	1800	190	200
3/4"	Cold start-up, Kg/hr	1814	2268	2721	2812
	Hot (Dripleg), Kg/hr	72	81	86	90
1"	Cold start-up, lbs/hr	9000	12000	14000	14200
	Hot (Dripleg), lbs/hr	800	1100	1500	1800
	Cold start-up, Kg/hr	4082	5443	6250	6441
	Hot (Dripleg), Kg/hr	362	498	680	816
1-1/2" & 2"	Cold start-up, lbs/hr	20000	22000	24000	28000
	Hot (Dripleg), lbs/hr	1200	2500	4000	5300
	Cold start-up, Kg/hr	9072	9979	10886	12700
	Hot (Dripleg), Kg/hr	544	1134	1814	2404
Model GM25		Consider "GM10" Series traps in this range			
Size	Operating Pressure, psi (bar)	150 (10,3)	200 (13,8)	250 (17,2)	320 (22,1)
1/2"	Cold start-up, lbs/hr	9000	12000	14000	14000
	Hot (Dripleg), lbs/hr	800	1000	1300	1500
3/4"	Cold start-up, Kg/hr	4082	5443	6350	6350
	Hot (Dripleg), Kg/hr	362	453	589	680

Note: Flow rates are based on discharge to atmospheric pressure, valid for back pressure up to 20% of inlet pressure. Higher back pressure requires reset of control element to obtain these capacities. Consult factory for details.