



3170 Wasson Road • Cincinnati, OH 45209 USA  
Phone 513-533-5600 • Fax 513-871-0105  
E-Mail: info@richardsind.com • www.jordanvalve.com

# I & M 68HP

## Installation & Maintenance Instructions for Mark 68HP High Pressure Regulators

**Warning:** Jordan Valve products must only be used, installed, and repaired in accordance with these Installation & Maintenance Instructions. Observe all applicable public and company codes and regulations. In the event of leakage or other malfunction, call a qualified service person; continued operation may cause system failure or a general hazard. Before servicing any valve, disconnect, shut off, or bypass all pressurized fluid. Before disassembling a valve, be sure to release all spring tension.

### Please read these instructions carefully!

Your Jordan Valve product will provide you with long, trouble-free service if it is correctly installed and maintained. Spending a few minutes now reading these instructions can save hours of trouble and downtime later. When making repairs, use only genuine Jordan Valve parts, available for immediate shipment from the factory.

### IDEAL INSTALLATION SCHEMATIC

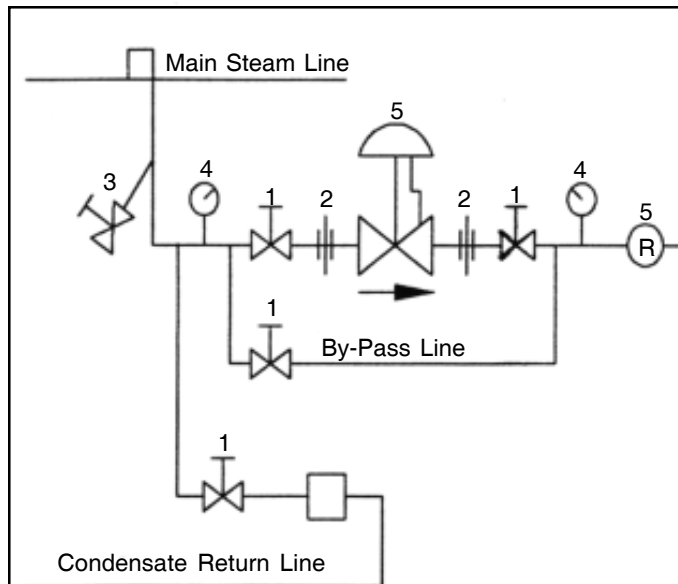

- 1 Shut Off Valve
- 2 Pipe Union
- 3 Strainer/Drain Valve
- 4 Pressure Gauge
- 5 Jordan MK68HP Pressure Regulator
- 6 Relief Valve
- 7 Steam Trap

### INSTALLATION

1. To protect the regulator from grit, scale, thread chips, and other foreign matter, all pipe lines and piping components should be blown out and thoroughly cleaned before the regulator is installed.
2. Shutoff valves, pressure gauges, and bypass piping should be installed as indicated in the **Ideal Installation Schematic** to provide easier adjustment, operation and testing.
3. When preparing threaded pipe connections, care should be exercised to prevent pipe sealing compound from getting into the pipe lines. Pipe sealing compound should be used sparingly, leaving the two lead threads clean. Jordan Valve uses, and recommends, thread sealer Teflon ribbon.
4. A line strainer should be installed on the inlet side of the regulator to protect it from grit, scale, and other foreign matter. A .033 perforated screen is usually suitable. Line strainers are available from Jordan Valve.
5. Install the regulator in the highest horizontal line of piping to provide drainage for the inlet and outlet piping, to prevent water hammer, and to obtain faster regulation.
6. The flow arrow on the regulator body must be pointed in the direction of flow. The regulator may be installed vertically or horizontally without affecting its operation.
7. For best control, 3'-0" straight sections of pipe should be installed on either side of the regulator.
8. In hot vapor lines, upstream and downstream piping near the regulator should be insulated to minimize condensation.
9. If possible, install a relief valve downstream from the regulator. Set at 15 psi above the control point of the regulator.
10. For gas service, expand the outlet piping at least one pipe size if the controlled pressure (downstream) is 25% of the inlet pressure or less. A standard tapered expander connected to the outlet of the regulator is recommended.
11. Where surges are severe, use a piping accumulator.
12. Operate the regulator within its rated pressure and temperature.

---

## Torque Procedure

---

1. Install all bolts hand-tight.
2. Torque the bolts in order of the bolt pattern to 75 in-lbs.
3. Re-torque each bolt to 300 in-lbs (25 ft-lbs) using the same bolt pattern as shown.

### Bolt Pattern/Torque Sequence

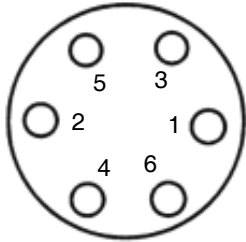

6 Bolts (or multiples)

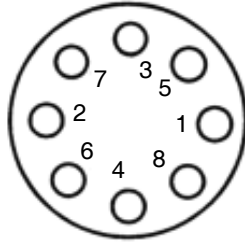

8 Bolts (or multiples)

---

## Ordering Spare Parts & Repairs

---

Jordan Valve products are ruggedly built, carefully assembled to accurate dimensions, and individually tested for performance. A complete stock of finished parts is maintained ready for immediate shipment.

If desired, Jordan Valve will promptly repair all regulators at a reasonable cost. To return a valve for inspection and/or repair, please contact our customer service department for a Return Authorization Number. Telephone toll-free 1-800-543-7311 (within the USA) or 1-800-354-0305 (from Canada). If preferred, you can fax us at 513-871-0105.

When requesting a return or when ordering spare parts, first make a note of the following information on the valve's name-plate:

- serial number
- model number and size
- body material and end connections
- range
- seat and seal materials

---

## Troubleshooting

---

### SYMPTOM- ERRATIC CONTROL

#### POSSIBLE CAUSE AND CURE:

Oversizing causes cycling and hunting and reduces the rangeability of the valve. Make certain that your sizing is correct.

Steam traps downstream may need attention.

Safety valve may be jammed open. Repair as necessary.

Excessive foreign matter on seat (4) or plug seat (3). Clean them. Inspect seating surfaces for deterioration.

Valve trim may not be moving freely. Check for any parts that may be binding.

### SYMPTOM: DOWNSTREAM PRESSURE BUILD-UP

#### POSSIBLE CAUSE AND CURE:

Seats deteriorated. Replace.

Inspect for foreign matter between the seat (4) and plug seat (3).

Valve trim may not be moving freely. Check for any parts that may be binding.

### SYMPTOM: CANNOT MAINTAIN REGULATED PRESSURE

#### POSSIBLE CAUSE AND CURE:

Clogged strainer or lines. Clean.

Inlet pressure too low.

Spring (15) set too low or broken. Reset or replace.

Valve is undersized for rated flow. Recheck sizing.

System demand exceeds capacity. Recheck sizing.